

## SPECIFICATION AND DESCRIPTION



# SKYHAWK 172S



December 2015

Revision A  
Units 172S-11662 to TBD



# SPECIFICATION AND DESCRIPTION



UNITS 172S-11662 TO TBD

DECEMBER 2015

REVISION A



## INTRODUCTION

This document is published for the purpose of providing general information for the evaluation of design, performance and equipment of the Cessna Skyhawk. Should more information be required, please contact:

Cessna Aircraft Company  
Single Engine Piston Aircraft  
2625 S. Hoover Rd.  
Wichita, Kansas 67215  
1-800-4-CESSNA  
[www.se.cessna.com](http://www.se.cessna.com)

This document supersedes all previous Specification and Description documents and describes only the Skyhawk Model 172S, its powerplant and equipment. Also included are the warranties applicable to the Skyhawk Model 172S aircraft, the Textron Lycoming IO-360-L2A engine, the McCauley propeller and the OEM-installed Garmin avionics. In the event of any conflict or discrepancy between this document and the basic purchase agreement, the basic purchase agreement language shall govern. Due to the time span between the date of this Specification and Description and the scheduled delivery date of the aircraft, Cessna reserves the right to revise the "Specification" whenever occasioned by product improvements, government regulations or other good cause.

## TABLE OF CONTENTS

### CESSNA SKYHAWK SPECIFICATION AND DESCRIPTION

SECTION	PAGE
1. General Description .....	3
1.1 Certification .....	3
1.2 Approximate Dimensions .....	6
1.3 Design Weights and Capacities .....	7
2. Performance .....	8
3. Powerplant & Accessories .....	8
4. Skyhawk Equipment List .....	9
5. Instrument Panel .....	10
6. Electrical Power .....	11
7. Engine Indicating System .....	11
8. Environmental .....	11
9. Exterior .....	12
10. Exterior Lights .....	12
11. Flight Controls .....	12
12. Fuel System .....	12
13. Interior .....	13
14. Interior Lighting .....	13
15. Exterior .....	13
16. Training .....	14
17. Limited Warranties .....	14
17.1 Cessna's Limited Warranty - Single Engine Piston Aircraft .....	14
17.2 Aircraft Paint and Graphics - Single Engine Piston Aircraft .....	15
17.3 Textron Lycoming Warranty (Limited) New Reciprocating Aircraft Engines .....	15
17.4 McCauley Propeller Systems Standard Limited Warranty .....	16
17.5 Garmin Avionics Installed in Single Engine Aircraft .....	18
FIGURE I — CESSNA SKYHAWK EXTERIOR DIMENSIONS .....	4
FIGURE II — CESSNA SKYHAWK INTERIOR DIMENSIONS .....	5
FIGURE III — CESSNA SKYHAWK INSTRUMENT PANEL .....	10

# **1. GENERAL DESCRIPTION**

## **1. GENERAL DESCRIPTION**

All information herein applies to the Skyhawk (Model 172S). The Skyhawk aircraft is an all-metal, single-engine piston, high-wing monoplane with a four-person seating capacity including a crew of one or two. Suitable allowance for luggage is provided.

### **1.1 CERTIFICATION**

The Model 172S is certified to the requirements of U.S. FAA Federal Aviation Regulation Part 23 through amendment 23-6, including day, night, VFR and IFR.

# 1. GENERAL DESCRIPTION (CONTINUED)

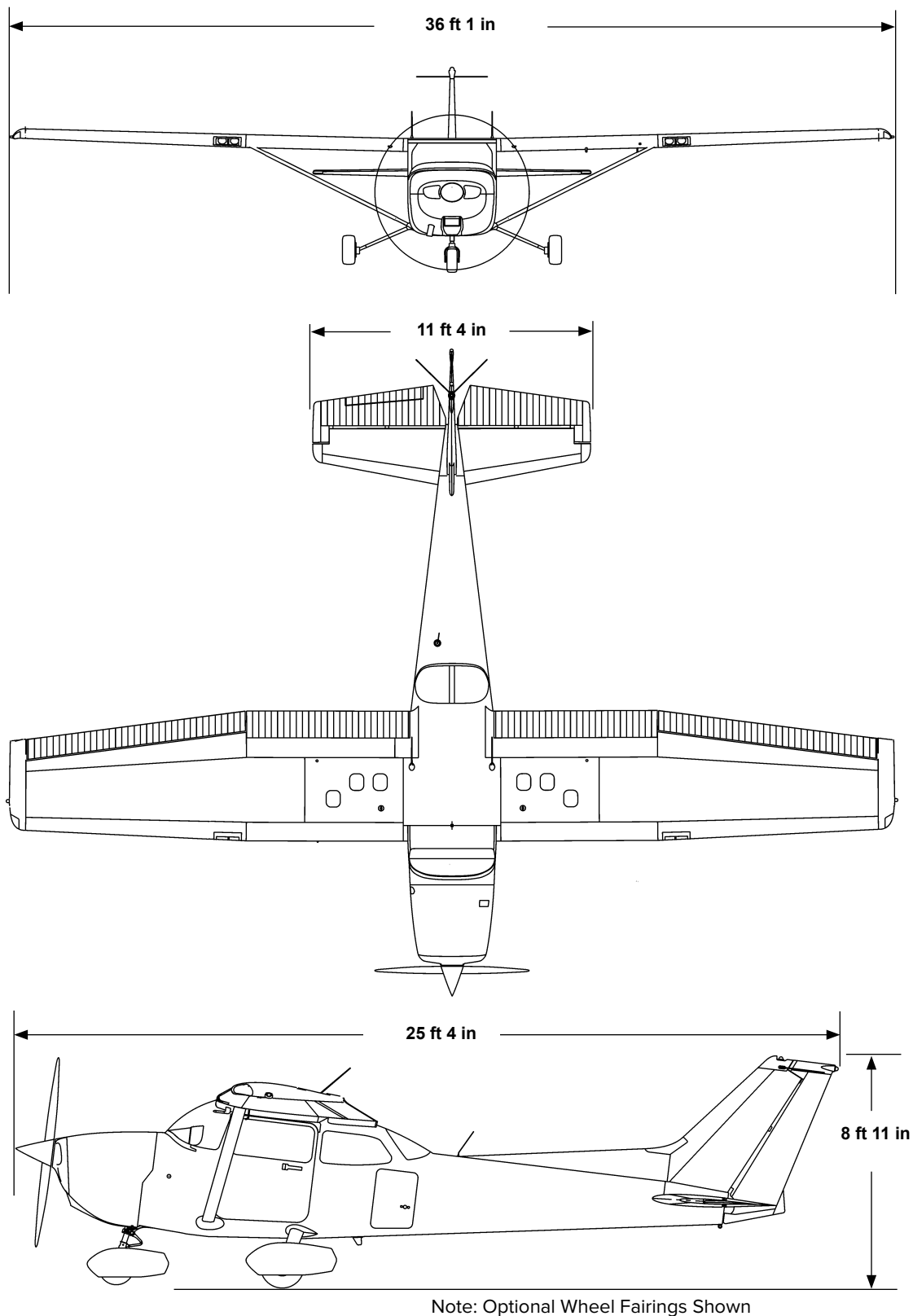

**FIGURE I — CESSNA SKYHAWK EXTERIOR DIMENSIONS**



# 1. GENERAL DESCRIPTION (CONTINUED)

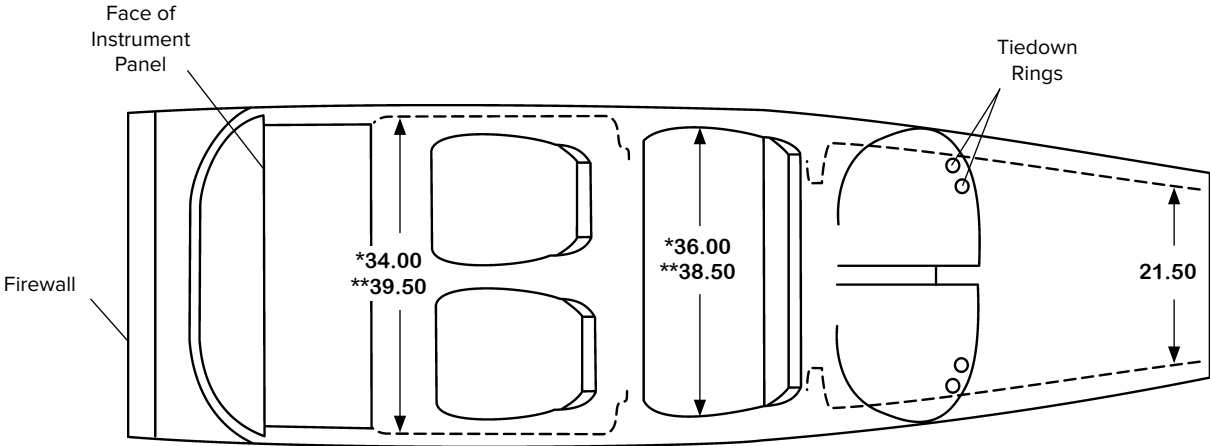
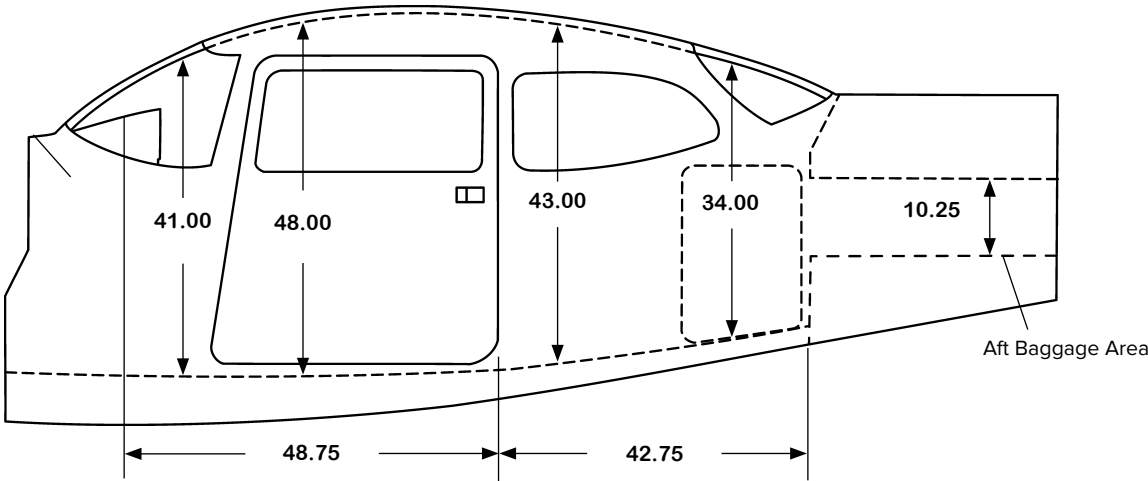

Code  
\*Cabin  
\*\*Lower Window Line

FIGURE II — CESSNA SKYHAWK INTERIOR DIMENSIONS

## 1. GENERAL DESCRIPTION (CONTINUED)

### 1.2 APPROXIMATE DIMENSIONS

Overall Height .....	8 ft 11 in (2.72 m)
Overall Length .....	27 ft 2 in (8.28 m)

#### WING

Span (overall) .....	36 ft 1 in (11.00 m)
Area .....	174 ft <sup>2</sup> (16.2 m <sup>2</sup> )

#### CABIN INTERIOR

Height (maximum) .....	48 in (1.22 m)
Width (trim to trim) .....	39.5 in (1.00 m)
Length (firewall to aft baggage bulkhead) .....	142 in (3.61 m)

#### CABIN DOOR

Height (front) .....	40.5 in (1.03 m)
Height (rear) .....	39 in (0.99 m)
Width (top) .....	32.5 in (0.83 m)
Width (bottom) .....	37 in (0.94 m)

#### BAGGAGE DOOR

Height (front) .....	22 in (0.56 m)
Height (rear) .....	21 in (0.53 m)
Width .....	15.3 in (0.39 m)

# 1. GENERAL DESCRIPTION (CONTINUED)

## 1.3 DESIGN WEIGHTS AND CAPACITIES

Standard Empty Weight ..... 1,641 lb (744 kg)

### RAMP WEIGHT

Normal Category ..... 2,558 lb (1,160 kg)

Utility Category ..... 2,208 lb (1,002 kg)

### TAKEOFF WEIGHT

Normal Category ..... 2,550 lb (1,157 kg)

Utility Category ..... 2,200 lb (998 kg)

### LANDING WEIGHT

Normal Category ..... 2,550 lb (1,157 kg)

### MAXIMUM USEFUL LOAD

Normal Category ..... 917 lb (415 kg)

Utility Category ..... 567 lb (257 kg)

### BAGGAGE ALLOWANCE

Normal Category ..... 120 lb (54 kg)

### FUEL CAPACITY

Total Capacity ..... 56 gal (212 L)

Total Useable ..... 53 gal (200.6 L)

Total Capacity (each tank) ..... 28 gal (106 L)

Total Useable Capacity (each tank) ..... 26.5 gal (100.3 L)

### OIL CAPACITY

Sump ..... 8 qts (7.6 L)

Total Capacity ..... 9 qts (8.5 L)

### NOTES

1. Standard empty weight based upon:
  - a) 0.6-mil primer on all details, 0.6-mil primer on all exterior surfaces and 2.0-mil paint on all exterior surfaces.
2. Total oil capacity is with 8 qts. in sump and 1 qt. in oil filter.

# CESSNA SKYHAWK

---

## 2. PERFORMANCE

All estimated performance data are based on airplane weights at 2,550 pounds; standard atmospheric conditions; level, hardsurface, dry runways; and no wind. They are calculated values derived from flight tests conducted by Cessna Aircraft Company under carefully documented conditions and will vary with individual airplanes, pilots, and numerous other factors affecting flight performance.

Service Ceiling .....	14,000 ft
Takeoff Distance S.L. (Ground Roll) .....	960 ft
Takeoff Distance S.L. (To Clear 50 ft. Obstacle) .....	1,630 ft
Maximum Climb Rate (S.L.) .....	730 fpm
Maximum Speed S.L. ....	126 kts / 145 mph
Maximum Range and Endurance .....	638 kts / 6.72 hrs
Cruise Speed (75% pwr at 8,500 ft) .....	124 kts / 143 mph
Cruise Range and Endurance (75% pwr at 8,500 ft) .....	518 nm / 4.26 hrs
Landing Distance (Ground Roll) .....	575 ft
Landing Distance (To Clear 50 ft. Obstacle) .....	1,335 ft

## 3. POWERPLANT & ACCESSORIES

- Lycoming IO-360-L2A Engine
- 180 HP @ 2700 RPM
- Certified for 100LL & 100 Fuel
- Fuel Injection System
- Tubular Steel Engine Mount
- Dynafocal Rear Mount
- Engine Driven Vacuum Pump
- Automatic Alternate Engine Air
- Oil Cooler
- Shock Mounted Cowling
- Induction Air Filter
- Full Flow Oil Filter
- Throttle Control
- Vernier Mixture Control
- Dual Ignition System, Shielded Magneto
- Engine Exhaust Muffler
- McCauley Fixed Pitch 2 – Blade Metal Propeller
- Propeller Spinner, Polished
- Electric Starter

## 4. SKYHAWK EQUIPMENT LIST

The following list of equipment is included on the standard aircraft and does not reflect optional equipment.

### Avionics

- GMA-1347 Digital Audio Panel w/Marker Beacon/ Intercom
- GTX-33 Transponder-Mode S w-TIS
- GIA-63W NAV/COM/GPS/WAAS w/GS #1
- GIA-63W NAV/COM/GPS/WAAS w/GS #2
- GDU-1040 Primary Flight Display (PFD)
- GDU-1040 Multi-Function Display (MFD)
- GEA-71 Engine/Airframe Computer
- GRS-77 Attitude & Heading Reference System (AHRS)
- GDC-74A Air Data Computer w/OAT Probe
- GMU-44 Magnetometer
- Garmin SafeTaxi & FliteCharts
- Electronic Checklists
- ME406 Two Frequency Emergency Locator Transmitter
- Emergency Locator Transmitter Remote Mounted Switch
- Backup Attitude Gyro, Altimeter and Airspeed Indicator
- Control Wheel Push-To-Talk Switch-Pilot/Copilot
- Mic & Phone Jacks-Pilot/Copilot/Passengers
- Auxiliary Stereo Input Jack
- Antennas:
  - Marker Beacon Antenna
  - Transponder Antenna
  - VHF/GPS Antenna (2)
  - NAV Antenna
  - Emergency Locator Transmitter External Antenna
- Pitot System - Heated
- Static System
- Hand Held Microphone
- Alternate Static Source
- Compass

## 5. INSTRUMENTATION

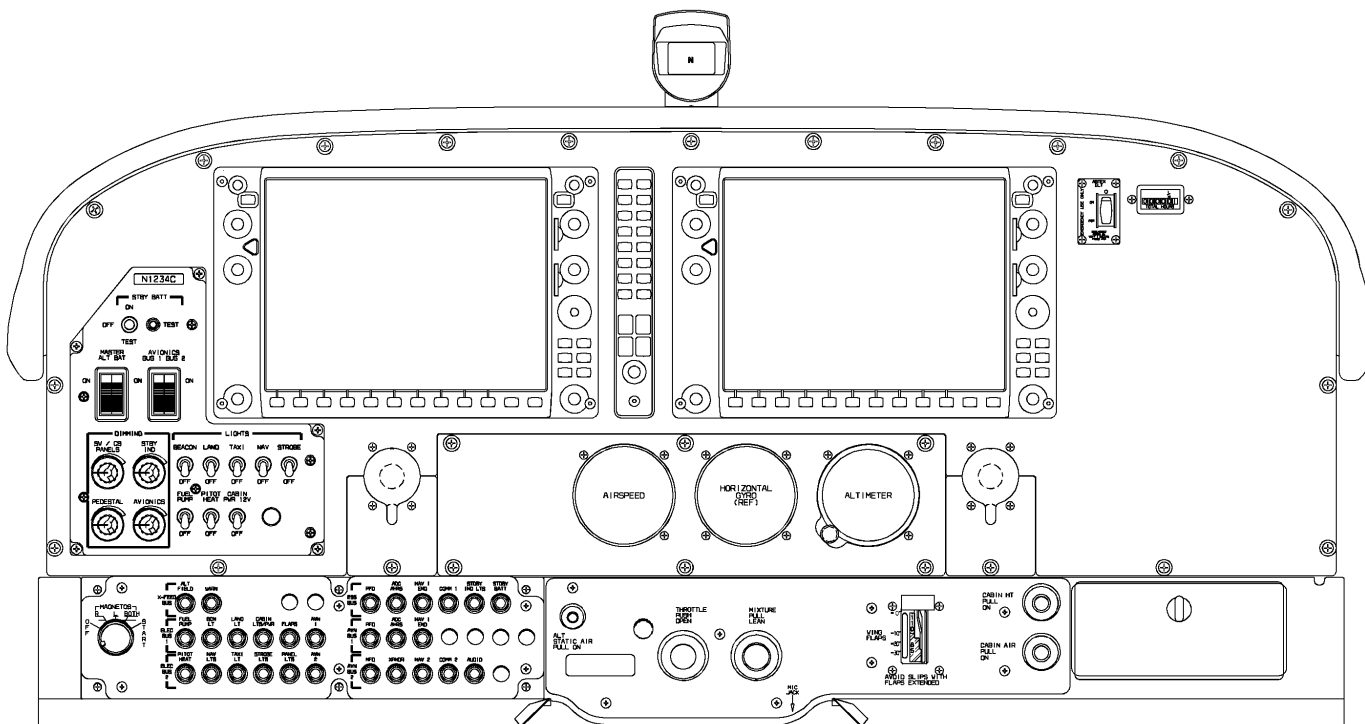

FIGURE III — CESSNA SKYHAWK INSTRUMENT PANEL

## 6. ELECTRICAL POWER

- Alternator, 28 Volt, 60 Amp
- Battery, 24 volt, 8.0 AH (1 hr rate), Manifold Type
- Standby Battery, 24 volt, 6.2 AH (1 hr rate), Sealed Type
- Standby Battery Controller
- Electrical Circuit Panel
  - Alternator/Battery Master Switch
  - Split Avionics Master Switch
  - Circuit Breakers, Electrical
  - Switches, Electrical
- Electrical J-Box
  - Alternator Control Unit
  - Ground Service Receptacle
  - Battery Current Sensor
  - Starter Relay
  - Alternator Relay
  - Battery Relay
  - Ground Power Relay
  - Bus Circuit Protection
- Cabin Power Jack - 12 Volt, 10 Amp

## 7. ENGINE INDICATING SYSTEM

- Ammeters
- Voltmeters
- Vacuum
- Oil Pressure and Temperature
- Tachometer - Hour Recorder
- Fuel Flow (GPH)
- LH/RH Fuel Quantity
- CHT - Cylinder Head Temperature
- EGT - Exhaust Gas Temperature
- Standby Vacuum System
- Annunciation – Caution and Warning
- Alerts (PFD)

## 8. ENVIRONMENTAL

- Windshield Defroster, Pilot/Copilot
- Ventilator, Adjustable (6 places)
- Heating System, Shrouded Muffler w/Firewall Valve
- Soundproofing
- Carbon Monoxide Detection System

## 9. EXTERIOR

- Epoxy Corrosion Proofing, All Structure
- LH Door, Pilot w/Hinged Window, Lock and Key
- RH Door, Copilot w/Hinged Window
- LH Baggage Door, w/Lock and Key
- Rear Window
- All Windows Tinted
- Gear Jack Pads
- Fixed Landing Gear
- White Polyurethane Exterior Paint
- Refueling Steps and Handles, Wing Struts and Fuselage
- Fixed Cabin Entrance Steps
- Tie Down Rings, LH/RH Wing & Tail and Nose
- Tube Type Tires
  - Nose - 5.00 X 5
  - Mains - 6.00 X 6
- Conical Camber Wing Tips
- Strut Braced, Camber Lift Wings
- Static Wicks

## 10. EXTERIOR LIGHTS

- LED Ground Recognition Beacon - Vertical Tail
- LED Navigation, LH/RH Wing Tip & Vertical Tail
- Wing Tip Navigation Light Detectors, LH/RH
- Wing Tip Strobe, LH/RH
- Dual Wing LED Landing and Taxi Lights with integrated Pulse Recognition Technology
- Underwing Courtesy, LH and RH Wing

## 11. FLIGHT CONTROLS

- Hydraulic Brakes, Toe-Operated
- Parking Brake
- Stainless Steel Control Cables
- Pilot/Copilot All Purpose Control Wheels
- Pilot control wheel
- Electrical Preselect - Flaps
- Dual Flight Controls -Aileron/Elevator/Rudder
- Steerable Nose Wheel
- Aileron and Elevator Control Lock
- Elevator Trim
- Pilot Control Wheel Switches
  - Pitch Trim

## 12. FUEL SYSTEM

- Electric Auxiliary Fuel Pump
- Engine Driven Fuel Pump
- Integral Fuel Tanks, 53 Gal. Usable
- Fuel Selector Valve, Left/Both/Right
- Fuel Shutoff
- Fuel Strainer, Incorporated with Fuselage Quick Drain
- Fuel Tank Quick Drain, 5 per wing
- Fuel Sampler Cup
- Fuel Vapor Return System



## 13. INTERIOR

- Warm Beige Luxor II Leather Seating Surface
- Door Panel, Upper Sidewall Accent - Beige Woven Vinyl
- Door, Lower Sidewall, Kick Panel - Black Kydex
- Vinyl Grip Flooring in Crew Area
- Carpeting in Passenger Area
- Pilot/ Copilot Amsafe Inflatable Seat Belts & Shoulder Harness STC, Inertia reel
- Rear Seat Bench with One Piece Reclining Back, Seat Belts & Shoulder Harness, Inertia Reel
- Passenger Side Wall
- Pilot and Copilot Seats
  - Adjustable Fore and Aft
  - Reclining Backs
  - Vertical Adjustment
- Pilot & Copilot Door Armrests
- Approach Plate Holder on Pilot Control Wheel
- Pilot's Check List
- Pilot's Operating Handbook
- Hand Held Fire Extinguisher
- Glareshield
- Clothes Hanger Bar
- Metal Instrument Panel, with Removable Subpanels
- Map/Glove Compartment
- Baggage Net
- Radio Call Plate
- Map & Storage Pockets
- Pilot/Copilot Sun Visors
- Passenger Cup Holders
- Jepp Manual Storage Console with Cup Holders
- Tow Bar

## 14. INTERIOR LIGHTING

- LED Pilot/Copilot Cabin Overhead LED Lights
- LED Passenger Overhead Light
- Interior Lights Dimming Control
- Map Light, Pilot Control Wheel
- Sub-Panel Lighting (LED Backlighting)
  - Flaps
  - Throttle
  - Mixture
  - Environmental Controls (Air and Heat)
- Switch Panel Lighting (LED Backlighting)
  - Avionics and Master Switches
  - Dimming Rheostats
  - Landing, Taxi and Nav Switches
  - Beacon, Strobe, Fuel Pump, Pitot Heat
- 12 volt Cabin Power
- Standby Battery Switch
- Circuit Breakers
- Ignition / Start Switch
- LCD Lighted Glass Panel Displays:
  - Electronic Flight Instruments
  - Electronic Avionics Instruments
  - Electronic Engine Instruments
- Audio Panel Bezel (Backlighting)
- Backup Attitude Gyro, Altimeter and Airspeed Indicator Internally Lighted
- Radio Call Plate (Backlighting)
- Compass Internally Lighted

## 15. EXTERIOR

Distinctive exterior styling in a variety of colors is provided.

## 16. TRAINING

Cessna will offer one G1000 training course at no additional charge and one G1000 ground school course for a second person at no additional charge, with purchase of a new aircraft. This offer is valid for 12 months after aircraft delivery.

## 17. LIMITED WARRANTIES

### 17.1 CESSNA'S LIMITED WARRANTY - SINGLE ENGINE PISTON AIRCRAFT

Seller warrants the aircraft and all parts included therein to be free from defects in material and workmanship under normal use and service for a period of twenty-four (24) months after the Warranty Start Date, except as hereafter noted. Engines, engine part accessories, avionics, batteries, propellers and governors are specifically excluded from this warranty. Paint and graphics warranties are addressed separately.

Spare parts sold by Seller, excluding engines, engine part accessories, avionics, batteries, propellers and governors are warranted for six (6) months after installation, except as hereafter noted.

Seller's obligation under this warranty is limited to repairing or replacing, at its option, with exchange, overhauled, or new parts, items found defective by Seller's examination which are returned at the owner's expense within the applicable twenty-four (24) or six (6) month period to any Cessna Service Station.

A new warranty period is not established for replacement parts. Replacement parts are warranted only for the remainder of the applicable twenty-four (24) or six (6) month original warranty period.

The repair or replacement of defective parts under this warranty will be made without charge to the owner for parts and labor for removal, installation and/or actual repair, except that the owner shall pay all import duties and sales and use taxes on replacements and repairs.

This limited warranty does not apply to parts subjected to misuse, negligence, improper installation, accident, alteration; repairs not authorized by Seller; normal maintenance services (cleaning, control rigging, brake and other mechanical adjustments, maintenance inspections, etc.); replacement of service items (light bulbs, brake linings, filters, hoses, tires, cowl mounts, etc.); or to normal deterioration of soft trim or appearance items (paint, upholstery, rubber-like items, etc.) due to corrosion, wear and exposure.

**WITH THE EXCEPTION OF THE WARRANTY OF TITLE, TO THE EXTENT ALLOWED BY APPLICABLE LAW, THIS WARRANTY IS EXPRESSLY IN LIEU OF ANY OTHER WARRANTIES, EXPRESSED OR IMPLIED IN FACT OR BY LAW, INCLUDING ANY IMPLIED WARRANTY OF MERCHANTABILITY OR FITNESS FOR A PARTICULAR PURPOSE. THE REMEDIES OF REPAIR OR REPLACEMENT AS ABOVE SET FORTH ARE THE ONLY REMEDIES UNDER THIS WARRANTY. Seller DISCLAIMS ANY OBLIGATION OR LIABILITY WHETHER IN CONTRACT OR IN TORT (AND WHETHER FOR NEGLIGENCE, STRICT LIABILITY, PRODUCT LIABILITY OR OTHERWISE), INCLUDING LOSS OF USE OF THE PRODUCT WARRANTED, LOSS OF TIME, INCONVENIENCE, COMMERCIAL LOSS OR ANY OTHER DIRECT, CONSEQUENTIAL, SPECIAL OR INCIDENTAL DAMAGES. THIS WARRANTY IS IN LIEU OF ANY OTHER OBLIGATION OR LIABILITY OF Seller OF ANY NATURE WHATSOEVER BY REASON OF THE MANUFACTURE, SALE OR LEASE OF SUCH AIRCRAFT PRODUCTS AND Seller NEITHER ASSUMES NOR AUTHORIZES ANYONE TO ASSUME FOR IT ANY OTHER OBLIGATION OR LIABILITY IN CONNECTION WITH SUCH AIRCRAFT PRODUCTS. COMPLIANCE WITH THIS LIMITED WARRANTY MAY BE AFFECTED IF EXPORT LICENSES ARE REQUIRED TO BE**

## 17. LIMITED WARRANTIES (CONTINUED)

### REQUESTED AND APPROVED BEFORE SPARE PARTS CAN BE SHIPPED TO CERTAIN FOREIGN COUNTRIES.

#### 17.2 AIRCRAFT PAINT AND GRAPHICS—SINGLE ENGINE PISTON AIRCRAFT

Seller endeavors to select and use high quality polyurethane paints from the leading manufacturers. Polyurethane paints and graphics are used because of their high gloss characteristics and ability to withstand dramatic temperature and pressure changes. The paint on your new aircraft will maintain its high gloss characteristics for an extended period of time provided it is cared for properly.

The painted exterior surfaces require an initial curing period which may be as long as ninety (90) days after the finish is applied. During this curing period, some precautions should be taken to avoid damaging the finish or interfering with the curing process. The finish should be cleaned only by washing with clean water and mild soap, followed by a water rinse and drying with a cloth or chamois. Do not use polish or wax, which would exclude air from the surface, during this ninety (90) day curing period. Once the finish has cured completely, it may be waxed with a good automotive wax, but power buffing should be avoided to prevent damage to the paint surface.

Normal paint maintenance will include but is not limited to; touchup of abrasion and wear of the paint on screws heads, around access panels, wing leading edges, vertical and horizontal stabilizer leading edges, windshield retainers and other leading edge surfaces including parts on the landing gear subject to damage or erosion from airborne particles. Proper maintenance includes keeping surfaces clean, polished, and touching up chipped or eroded areas to prevent further damage and corrosion.

Paint and graphics warranty applies only to defects in material and workmanship for a period of one (1) year from the Warranty Start Date. Deterioration of paint and graphics due to normal wear, exposure, or improper care is not covered by the warranty. If proper paint maintenance procedures have been followed and paint peeling, blistering or cracking is evident in areas other than immediate leading edge sur-

faces, warranty consideration may be requested through a Cessna Service Station.

Generally speaking, warranty repair of paint is confined to a limited surface area. Workmanship or material defects can usually be identified to localized surface areas that were improperly prepared prior to paint application, or to areas where the paint or subsurface primer has been improperly applied.

Complete strip and repaint of an entire airplane can ONLY be authorized if there is evidence of paint defects on several major surface areas of the aircraft. Contact your Cessna Field Service Engineer concerning paint defects on any major surface of an aircraft.

#### 17.3 TEXTRON LYCOMING WARRANTY (LIMITED) NEW RECIPROCATING AIRCRAFT ENGINE

##### What Textron Lycoming Promises You

Engine Model Aircraft Model

IO-360-L2A Cessna-172R, 172S

IO-540-AB1A5 Cessna-182T

IO-540-AC1A5 Cessna-206H

TIO-540-AK1A Cessna-T182T

TIO-540-AJ1A Cessna-T206H

Textron Lycoming warrants the above listed new reciprocating engine models sold by it to be free from defects in material and workmanship for a period of twenty-four (24) months after aircraft delivery to the original retail purchaser or first user. The date of first operation must not exceed two (2) years from the date of shipment from Textron Lycoming.

Textron Lycoming's obligation under this warranty shall be limited to its choice of repair or replacement, on an exchange basis, of the engine or any part of the engine, when Textron Lycoming has determined that the engine is defective in material or workmanship. Such repair or replacement

## 17. LIMITED WARRANTIES (CONTINUED)

will be made by Textron Lycoming at no charge to you. Textron Lycoming will also bear the cost for labor in connection with the repair or replacement as provided in Textron Lycoming's then current Removal and Installation Labor Allowance Guidebook.

Any engine or part so repaired or replaced will be entitled to warranty for the remainder of the original warranty period.

### YOUR OBLIGATIONS

The engine must have received normal use and service. You must apply for warranty with an authorized Textron Lycoming distributor within 30 days of the appearance of the defect in material or workmanship.

Textron Lycoming's warranty does not cover normal maintenance expenses or consumable items, the obligations on the part of Textron Lycoming set forth above are your exclusive remedy and the exclusive liability of Textron Lycoming. This warranty allocates the risk of product failure between you and Textron Lycoming, as permitted by applicable law.

Textron Lycoming reserves the right to deny any warranty claim if it reasonably determines that the engine or part has been subject to accident or used, adjusted, altered, handled, maintained, or stored other than as directed in your operator's manual, or if non-genuine Textron Lycoming parts are installed in or on the engine and are determined to be a possible cause of the incident for which the warranty application is filed.

Textron Lycoming may change the construction of engines at any time without incurring any obligation to incorporate such alterations in engines or parts previously sold.

**THIS LIMITED WARRANTY IS EXCLUSIVE AND IN LIEU OF ALL OTHER WARRANTIES AND REPRESENTATIONS, EXPRESS OR IMPLIED OR STATUTORY, WHETHER WRITTEN OR ORAL, INCLUDING BUT NOT LIMITED TO ANY WARRANTY OF MERCHANTABILITY OR FITNESS FOR ANY PARTICULAR PURPOSE, AND ANY IMPLIED WARRANTY ARISING FROM ANY COURSE OF PERFORMANCE OR DEALING OR TRADE USAGE. THIS WARRANTY IS ALSO IN LIEU OF ANY OTHER OBLIGATION, LIABILITY, RIGHT,**

**OR CLAIM, WHETHER IN CONTRACT OR IN TORT, INCLUDING ANY RIGHT IN STRICT LIABILITY IN TORT OR ANY RIGHT ARISING FROM NEGLIGENCE ON THE PART OF TEXTRON LYCOMING, AND TEXTRON LYCOMING'S LIABILITY ON SUCH CLAIM SHALL IN NO CASE EXCEED THE PRICE ALLOCABLE TO THE ENGINE OR PART WHICH GIVES RISE TO THE CLAIM.**

**LIMITATION OF LIABILITY IN NO EVENT, WHETHER AS A RESULT OF A BREACH OF WARRANTY, CONTRACT, OR ALLEGED NEGLIGENCE, SHALL TEXTRON LYCOMING BE LIABLE FOR SPECIAL OR CONSEQUENTIAL OR ANY OTHER DAMAGES, INCLUDING BUT NOT LIMITED TO LOSS OF PROFITS OR REVENUES, LOSS OF USE OF THE ENGINE, OR COST OF A REPLACEMENT.**

No agreement varying this warranty or Textron Lycoming's obligations under it will be binding upon Textron Lycoming unless in writing signed by a duly authorized representative of Textron Lycoming.

Cessna Model Aircraft Only

Textron Lycoming Engines

652 Oliver Street

Williamsport, Pennsylvania 17701

(570) 323-6181

[www.lycoming.textron.com](http://www.lycoming.textron.com)

Original Engine Installation Only

Effective 2000

### 17.4 MCCAULEY PROPELLER SYSTEMS STANDARD LIMITED WARRANTY

McCauley Propeller Systems, a Division of Textron Aviation, Wichita, Kansas, U.S.A., expressly warrants new and remanufactured products produced and sold by McCauley to be free from defects in material and workmanship under normal use and service for a period of thirty-six (36) months

## 17. LIMITED WARRANTIES (CONTINUED)

after delivery to the original retail purchaser or until the expiration of the maximum hours of use or calendar limits for overhaul published by McCauley for the subject product, whichever occurs first.

McCauley's obligation under this limited warranty is limited to repairing or replacing, at its sole option, any propeller, propeller parts, governor or governor parts determined by McCauley to have been defective and which are properly returned by the owner, with a written statement describing the alleged defect, to any McCauley Authorized Service Center authorized to service the individual McCauley product. The repair or replacement of defective parts will be made without charge to the owner for parts, or labor for removal and installation, except export/import duties, and/or sales or use taxes, if any which are solely the owner's responsibility. McCauley will warrant a part replaced pursuant to this limited warranty under the same terms as the original part for the remainder of the applicable warranty period of the original part. This limited warranty is not intended to and does not cover the costs of normal maintenance of overhaul.

In addition, McCauley will repair or replace, at its option, any propeller, propeller parts, governor, or governor parts requiring replacement due to manufacturing defect if found at or before the first recommended overhaul interval as described in McCauley published service information. This first overhaul coverage does not include labor, standard overhaul replacement parts, parts repairable via published service information (re-plating, painting, etc.), other costs associated with the propeller or governor overhaul, or export/import duties, and/or sales or use taxes, nor does it apply to defects found after McCauley published overhaul hour or calendar limits. The provisions of this limited warranty do not apply to: any McCauley parts which have been subject to misuse, negligence or accident or which have been repaired or altered in any way that, in the sole judgment of McCauley, adversely affects their performance, stability or reliability; to normal maintenance services (such as cleaning, mechanical adjustments and maintenance inspections); to the replacement of service items made in connection with normal maintenance; to normal deterioration of soft trim and appearance items (such as paint and rubber-like

items) due to wear and exposure; to propellers, governors or parts found defective beyond the McCauley recommended overhaul period; or to parts which have been improperly installed by entities other than McCauley and/or McCauley Authorized Service Centers.

The McCauley limited warranty is void on any new or re-manufactured product installed, without McCauley's prior written approval, on a non-type certificated engine, or on any engine which has received an overhaul or modification which is not approved by the engine manufacturer and that results in a change to the vibratory environment of the engine such as, but not limited to, an alteration of horsepower, operating RPM, crankshaft damper configuration, compression ratio, magneto timing, camshaft design, or any other overhaul or modification not expressly approved by the original engine manufacturer. The McCauley limited warranty is also void on any McCauley product shipped new from the factory or distributor in disassembled state, then later re-assembled by an unauthorized party. Parties authorized to re-assemble factory-new product must have specific written permission from McCauley to do so, otherwise all McCauley warranty on the affected unit is void. No McCauley warranty coverage is offered for leakage on product assembled outside McCauley, regardless of the assembling party.

To the extent allowed by applicable law, **THIS WARRANTY IS EXPRESSLY IN LIEU OF ANY OTHER WARRANTIES, EXPRESSED OR IMPLIED IN FACT OR BY LAW, INCLUDING ANY IMPLIED WARRANTY OF MERCHANTABILITY OR FITNESS FOR A PARTICULAR PURPOSE. THE REMEDIES OF REPAIR OR REPLACEMENT SET FORTH HEREIN ARE THE ONLY REMEDIES UNDER THIS LIMITED WARRANTY. McCAULEY DISCLAIMS ANY OBLIGATION OR LIABILITY, WHETHER IN CONTRACT OR IN TORT, INCLUDING LOSS OF USE OF THE PRODUCT WARRANTED, LOSS OF TIME, INCONVENIENCE, LOSS OF PROFITS, COMMERCIAL LOSS, OR ANY OTHER DIRECT, CONSEQUENTIAL, SPECIAL, OR INCIDENTAL DAMAGES. THIS WARRANTY IS IN LIEU OF ANY OBLIGATION OR LIABILITY ON THE PART OF McCAULEY TO ANYONE OF ANY NATURE WHATSOEVER BY REASON OF THE MANUFACTURE, SALE, LEASE,**

## 17. LIMITED WARRANTIES (CONTINUED)

**OR USE OF THE WARRANTED PRODUCTS AND McCAULEY NEITHER ASSUMES NOR AUTHORIZES ANYONE TO ASSUME FOR IT ANY OTHER OBLIGATION OR LIABILITY IN CONNECTION WITH SUCH WARRANTED PRODUCTS. THE UNITED NATIONS CONVENTION ON CONTRACTS FOR THE INTERNATIONAL SALE OF GOODS, 1980, AND ANY SUCCESSOR THERETO, IS EXPRESSLY EXCLUDED FROM THIS WARRANTY.**

Issued 9/1/2003

### 17.5 GARMIN AVIONICS INSTALLED IN SINGLE ENGINE AIRCRAFT

#### **Aircraft OEM-Installed Avionics 2-Year Limited Warranty Policy**

This GARMIN Product is warranted to be free from defects in materials or workmanship for two years from the date of warranty activation. Within this period, GARMIN International, Inc. will at its sole option, repair or replace any components which fail in normal use. Such repairs or replacement will be made at no charge to the customer for parts or labor, provided that the customer shall be responsible for any transportation cost. This warranty does not cover failures due to abuse, misuse, accident or unauthorized alteration or repairs.

**THE WARRANTIES AND REMEDIES CONTAINED HEREIN ARE EXCLUSIVE AND IN LIEU OF ALL OTHER WARRANTIES EXPRESS OR IMPLIED OR STATUTORY, INCLUDING ANY LIABILITY ARISING UNDER ANY WARRANTY OF MERCHANTABILITY OR FITNESS FOR A PARTICULAR PURPOSE, STATUTORY OR OTHERWISE. THIS WARRANTY GIVES YOU SPECIFIC LEGAL RIGHTS, WHICH MAY VARY FROM STATE TO STATE.**

**IN NO EVENT SHALL GARMIN BE LIABLE FOR ANY INCIDENTAL, SPECIAL, INDIRECT OR CONSEQUENTIAL DAMAGES, WHETHER RESULTING FROM THE USE, MISUSE OR INABILITY TO USE THIS PRODUCT OR FROM DEFECTS IN THE PRODUCT.** Some states do not allow the exclusion of incidental or consequential damages, so the above limitations may not apply to you.

GARMIN retains the exclusive right to repair or replace the product or offer a full refund of the purchase price at its sole discretion. **SUCH REMEDY SHALL BE YOUR SOLE AND EXCLUSIVE REMEDY FOR ANY BREACH OF WARRANTY.**

To obtain warranty service, contact your local GARMIN authorized Service Center. For assistance in locating a Service Center near you, call GARMIN Customer Service at one of the numbers shown below.

GARMIN International  
1200 East 151st Street  
Olathe, Kansas 66062, U.S.A.

Toll free: 1-800-800-1020

Phone: 1-913-397-8200

FAX: 1-913-397-0836

GARMIN (Europe) Ltd.  
Unit 5, The Quadrangle  
Abbey Park Industrial Estate

Romsey, SO51 9AQ, U.K.

Phone: 44-1794-519944

FAX: 44-1794-519222

**Visit our web site at: [www.garmin.com](http://www.garmin.com)**





**U.S. + 1.844.44.TXTAV | INTERNATIONAL +1.316.517.8270 | TXTAV.COM**

© 2015 **Textron Aviation Inc.** The names of aircraft manufactured by Textron Aviation Inc. ("TAI") (or formerly by its subsidiaries Cessna Aircraft Company ("Cessna") and Beechcraft Corporation ("Beechcraft") including Hawker aircraft); some names for products or services of TAI, Cessna, Beechcraft or their subsidiaries, and logos are registered trademarks or registered service marks or trademarks or service marks of Textron Innovation Inc., used by permission, or Beechcraft whether or not appearing in large print, with trade marking symbols or otherwise denoting rights to or ownership of the same. Third party products names, marks, etc., whether or not appearing in large print or with trade marking symbols or otherwise denoting right or ownership of the same, belong to their respective owners.

December 2015  
SD-PIST-172S-1215