



**KING AIR C90GTx**



**KING AIR C90GTx**

# Turn long-range planning into long-range reality.

The Beechcraft® King Air® is more than just a business icon. For generations, the King Air 90 series has delivered the means to go more places, with more people, in more comfort, at less cost. It is little wonder that, today, King Air stands as the most popular business aircraft in the world. All over the world. What's more, the same things that have made it the most popular in the past and present, also make it the most relevant and useful for the future. This hard-won reputation—based on performance, quality and reliability—is reflected in the enthusiastic loyalty of our owners. Just ask one. Then talk to us.



[Beechcraft.com](http://Beechcraft.com)

# KING AIR C90GTx



## Bring Your “A” Game Wherever

Rugged landing gear and short takeoff and landing performance let you fly into and out of more airfields around the world.



## Better Tips for Success

Adding composite winglets improves climb performance, while increased gross weight dramatically increases payload capabilities.



## A Pilot's Dream Flight Deck

Rockwell Collins® Pro Line 21™ avionics are safe, intuitive and an easy transition for pilots stepping up from piston-powered aircraft.



## Welcome Quiet Comfort Aboard

The luxuriously appointed square-oval cabin offers more room for passengers and stowage, without the squeeze of light-jet interiors.

## A ride you'll never forget. Not that you would want to.

The King Air name is a beacon in the world of private aviation, inspiring pilots who have experienced the thrill of twin-turbine aircraft and who desire to own the very best. When pilots step up to the Beechcraft King Air C90GTx, they enter a whole new world of flying that offers the impressive King Air qualities of performance, excitement and predictable handling, combined with comfort, reliability and safety born from decades of perfecting the proven King Air design. Boasting features and capabilities that make this versatile workhorse an enviable alternative to VLJs, the King Air C90GTx offers

even greater range and payload than its predecessor, thanks to improvements like composite winglets for better fuel efficiency and climb performance. The new C90GTx features advanced swept-blade propellers that cut nearly 600 feet off your runway requirements, and dual aft strakes improve control and handling. Advanced avionics—the same glass cockpit found in jets costing millions more—are simple, intuitive and make pilots feel at home in what's certain to become their favorite new aircraft.

## KING AIR C90GTx



**Access to short and unimproved runways lets you go places others never will.** Boasting the best short-field performance of any business turboprop, the King Air's rugged landing gear and robust airframe make gravel runways, dirt strips and remote airfields as accessible as big-city airline hubs. Ready to take on anything in its path, the King Air can take off over a 50-foot obstacle in just 1,984 feet. Hot- and high-altitude departure scenarios are no problem, while low takeoff and approach speeds put pilots moving up from piston-powered aircraft at ease. Taking on all terrains is what the C90GTx was made to do, with the proven reliability that has given King Air its reputation as the most capable and trusted turboprop aircraft in the world.

**Announce that you've arrived in more places.**



Due to its impressive short-field performance, the King Air C90GTx gives you access to tens of thousands of airfields around the world.

## KING AIR C90GTx



**Continuing the tradition of versatility, ruggedness, comfort and quality.** As the newest member in the legendary King Air line, the C90GTx maintains a tradition of excellence set forth by its predecessors, while adding improvements across the board. Advanced swept-blade propellers and dual aft body strakes improve runway performance and handling, while an increased maximum takeoff weight permits more payload and fuel for your missions, and composite winglets provide better aerodynamics and efficiency. The new C90GTx delivers comprehensive capability.

**272 knots maximum cruise speed**

**Twin Pratt & Whitney™ Canada PT6A turboprop engines  
(combined 1,100 shp output)**

**More than 1,200 nautical mile range**

**30,000 feet (9,144 m) maximum operating altitude**



# Dramatically expand your range of influence.



**A step up. Way up.** Improved range and efficiency combined with proven reliability make the King Air C90GTx the number-one choice for owner-pilots and value-conscious corporations stepping up to the turboprop class.

# KING AIR C90GTx



Rockwell Collins® Pro Line 21™ Avionics Suite  
Three-Screen Electronic Flight Instrument System (EFIS)  
Integrated Flight Information System  
Engine Indicating System (EIS)

Dual Air Data Computers and Altitude Encoders  
Dual Attitude Heading Reference Systems (AHRS)  
Flight Management System (FMS) with Database Input Unit  
MDC-3000 Maintenance Diagnostic Computer

# Empowering the most important part of the aircraft. The pilot.



**This flight deck says you've arrived.** Step onto the flight deck of the King Air C90GTx, and most pilots will think they've stepped onto a business jet costing millions more. The latest Rockwell Collins® Pro Line 21™ avionics provide superior situational awareness, making this King Air easy for one pilot to operate, while those accustomed to piston-powered twins will feel at home. Features include electronic charts and a graphical weather display to minimize pilot fatigue. An enhanced ground proximity warning system (TAWS+), wind shear alert and a traffic collision avoidance system (TCAS I) help pilots fly safely, day and night.

[Beechcraft.com](http://Beechcraft.com)



# Keep your profile sleek and your comfort roomy.



Shown with optional aft partition.



A square-oval cabin cross-section lets passengers sit up straight in quintessential King Air comfort.

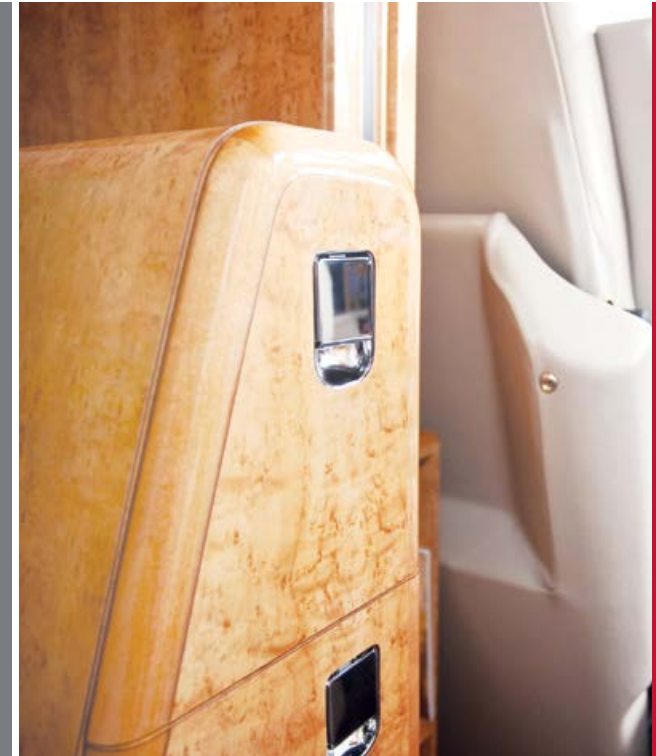

## Leather club seating

## Cabin windows with adjustable polarization

More than 300 cubic foot (8.50 cu m) interior is nearly 50% larger than the nearest light-jet competitor

48 cubic feet (1.36 cu m) of aft stowage is pressurized, heated and accessible in flight

Private aft lavatory

**It not only gets you to faraway places, it does it in style.** Uncommonly quiet and comfortable, the King Air C90GTx carries up to seven passengers in a cabin that offers a new standard of comfort simply unmatched by very light jets. Club-style seats swivel and recline, and passengers sit up straight, courtesy of a square-oval cabin design that provides extra room for shoulders and heads. With convenient refreshment cabinets, a private aft lavatory and a stowage compartment accessible in flight, everything passengers may need is easily within reach.

[Beechcraft.com](http://Beechcraft.com)

## KING AIR C90GTx

# Aircraft that set us apart. Support that goes even further.

### Tip-to-Tail Warranty

Textron Aviation Customer Service:  
General aviation's largest technical and field  
support network Available with ProAdvantage™



**Owning the world's most popular aircraft has its privileges.** Among them, a global service and support organization that is second to none. Our continuing investment in Textron Aviation Customer Service—the largest and most accessible network of its kind—is our investment in the success of your business and your satisfaction as a Beechcraft owner. With the industry's most respected experts, state-of-the-art facilities and providing mobile response teams to remote destinations, we deliver daily on our promise.

### **Inquire about the Beechcraft King Air C90GTx:**

U.S. and the Americas **+1.316.676.0800**

Asia-Pacific **+10.6568.8189**

EMEA **+44(0) 1244.493.851**

**SPECIFICATIONS**

	STANDARD	METRIC
Seating Configuration (Crew + Standard Pax/Max. Pax)	1 + 7 / 9	

**AVIONICS**

Manufacturer	Rockwell Collins	
Suite	Pro Line 21	

**ENGINES**

Manufacturer	Pratt & Whitney Canada	
Type	PT6A-135A	
Power Rating	550 shp	410 kW

**DIMENSIONS**

## EXTERNAL

Wingspan	53 ft 8 in	16.36 m
Max. Airplane Length	35 ft 6 in	10.82 m
Max. Tail Height	14 ft 3 in	4.34 m

## INTERNAL (CABIN)

Length	12 ft 7 in	3.84 m
Width	4 ft 6 in	1.37 m
Height	4 ft 9 in	1.45 m
Baggage Capacity	48.3 cu ft	1.37 cu m
Max. Baggage Weight	350 lb	159 kg

**WEIGHTS**

Max. Ramp Weight	10,560 lb	4,790 kg
Max. Takeoff Weight	10,485 lb	4,756 kg
Max. Zero Fuel Weight	9,378 lb	4,254 kg
Max. Landing Weight	9,832 lb	4,460 kg
Usable Fuel Capacity	2,573 lb	1,167 kg
Basic Operating Weight (w/ 1 pilot)	7,270 lb	3,298 kg
Max. Payload	2,108 lb	956 kg
Useful Load	3,290 lb	1,492 kg

**PERFORMANCE**

Max. Cruise Speed	272 kt	504 km/h
Range: Max. Payload	279 nm	517 km
Range: Full Fuel/Available Payload	1,183 nm	2,191 km
Range: 4 Passengers	1,127 nm	2,087 km
Range: Ferry	1,260 nm	2,334 km
Max. Operating Altitude	30,000 ft	9,144 m
Takeoff Distance (MTOW)	1,984 ft	605 m
Landing Distance (MLW)	2,100 ft	640 m

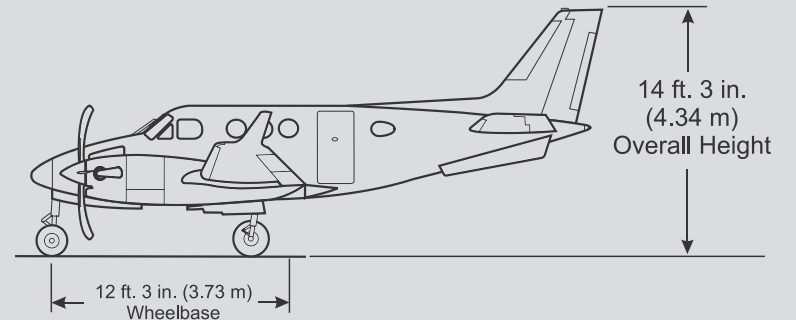
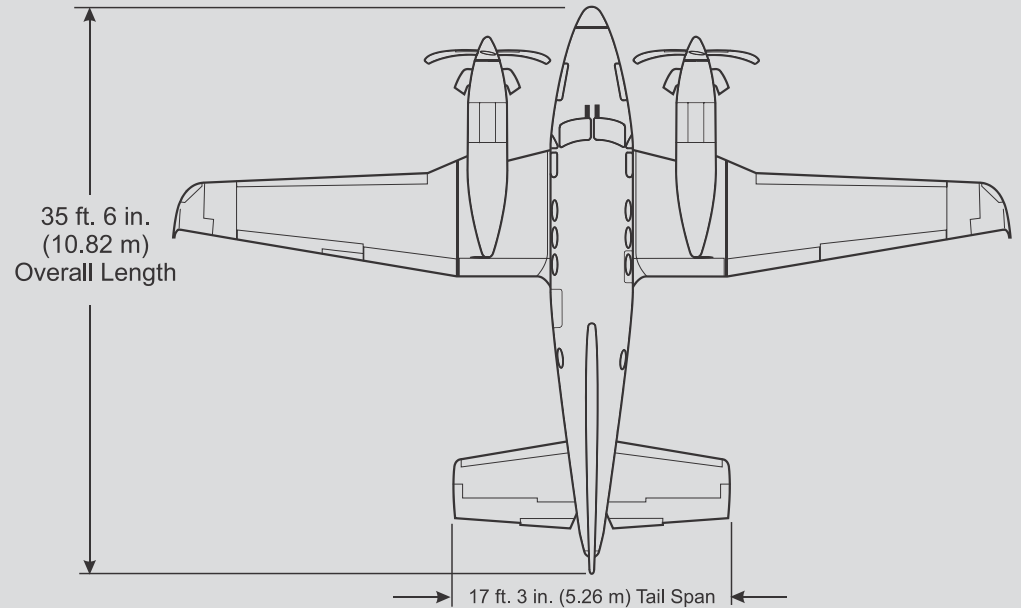
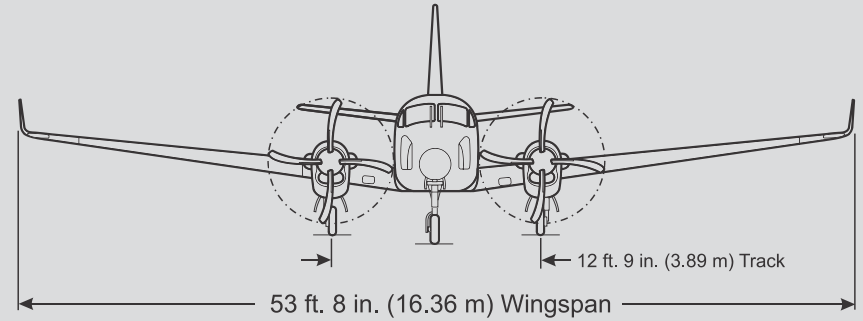



Visit [Beechcraft.com](http://Beechcraft.com) or contact a sales rep: U.S. and the Americas **+1.316.676.0800** | Asia-Pacific **+10.6568.8189** | EMEA **+44(0) 1244.493.851**

Images may show optional equipment. ©2014 Beechcraft Corporation. All rights reserved. Beechcraft is a registered trademark of Beechcraft Corporation. This document contains information from the relevant manufacturer or from independent sources. Although every attempt is made to ensure accuracy, no guarantee of actual performance or cost of operation is made or implied by Beechcraft Corporation or its subsidiaries. Data is subject to change without prior notification.

**Beechcraft**  
*We build aircraft you can believe in.\**

**TEXTRON AVIATION**

PROP-BROCH-C90GTX-1014